

STEP 1

Remove End Caps / End Plates if necessary.
Procedure starts with Butt Cut ends.

STEP 2

Remove Top Spacer.

STEP 3

Remove Bottom Spacer being held in place by two
Support Springs.

STEP 4

HT Blades: Remove Blade.

VT Blades: Remove Blade and Pins.

STEP 5

Replace Bottom Spacer to hold the frame in place
for cutting.

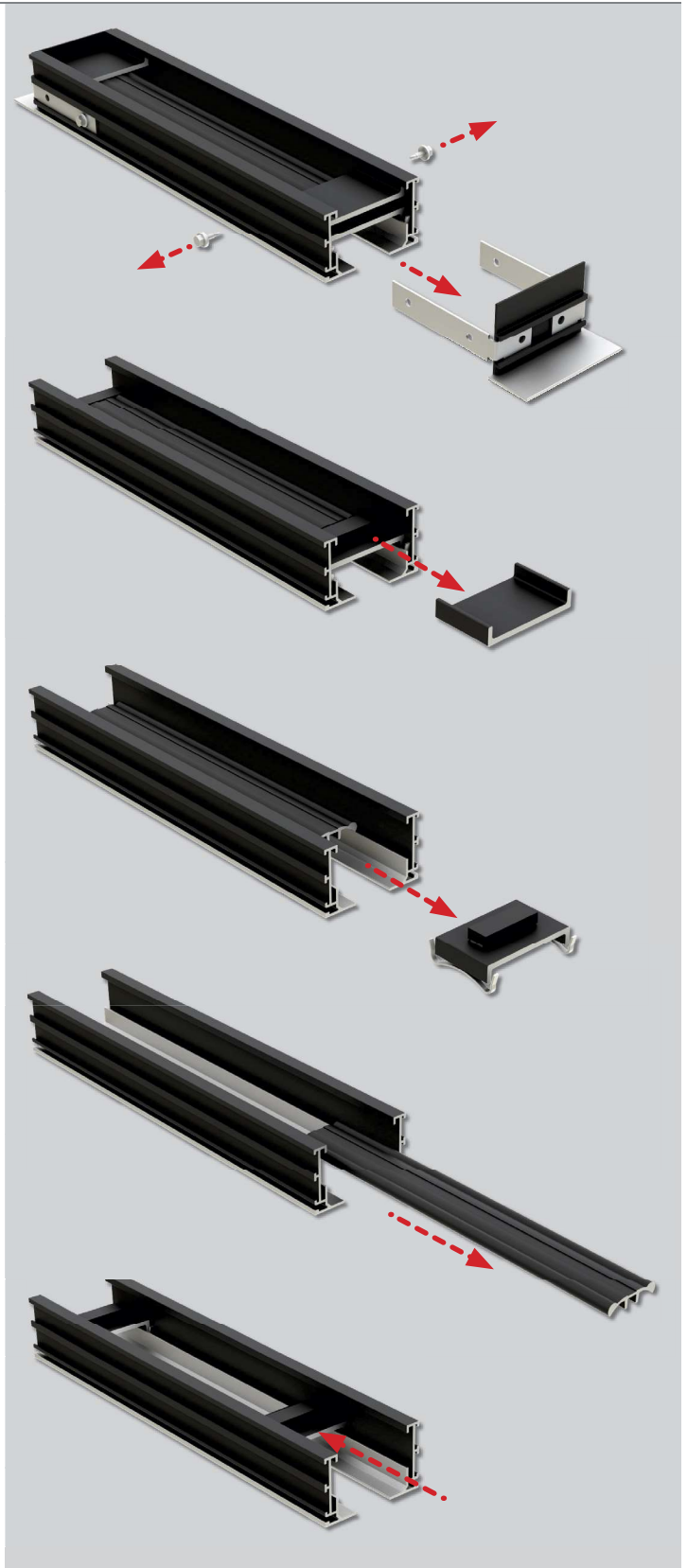

STEP 6

Cut off the desired length from the frame.
Remove the Bottom Spacer after cutting.

STEP 7

Trim the blade the same amount that the frame was trimmed. For example, if 3" of frame was cut off to shorten the unit, you need to cut 3" off the blade length.

STEP 8

Reinstall the Bottom Spacer with the two Support Springs.

STEP 9

HT Blade: Reinstall the Blade. Lay Blade on top of the Bottom Spacer with edge of the Blade against the Bottom Spacer Stop Block.

VT Blade: Reinstall the Blade. Insert Pin into Bottom Spacer Wing Clip. Slide Blade onto end of Pin that is sticking out of the Wing Clip.

STEP 10

Reinstall the Top Spacer.

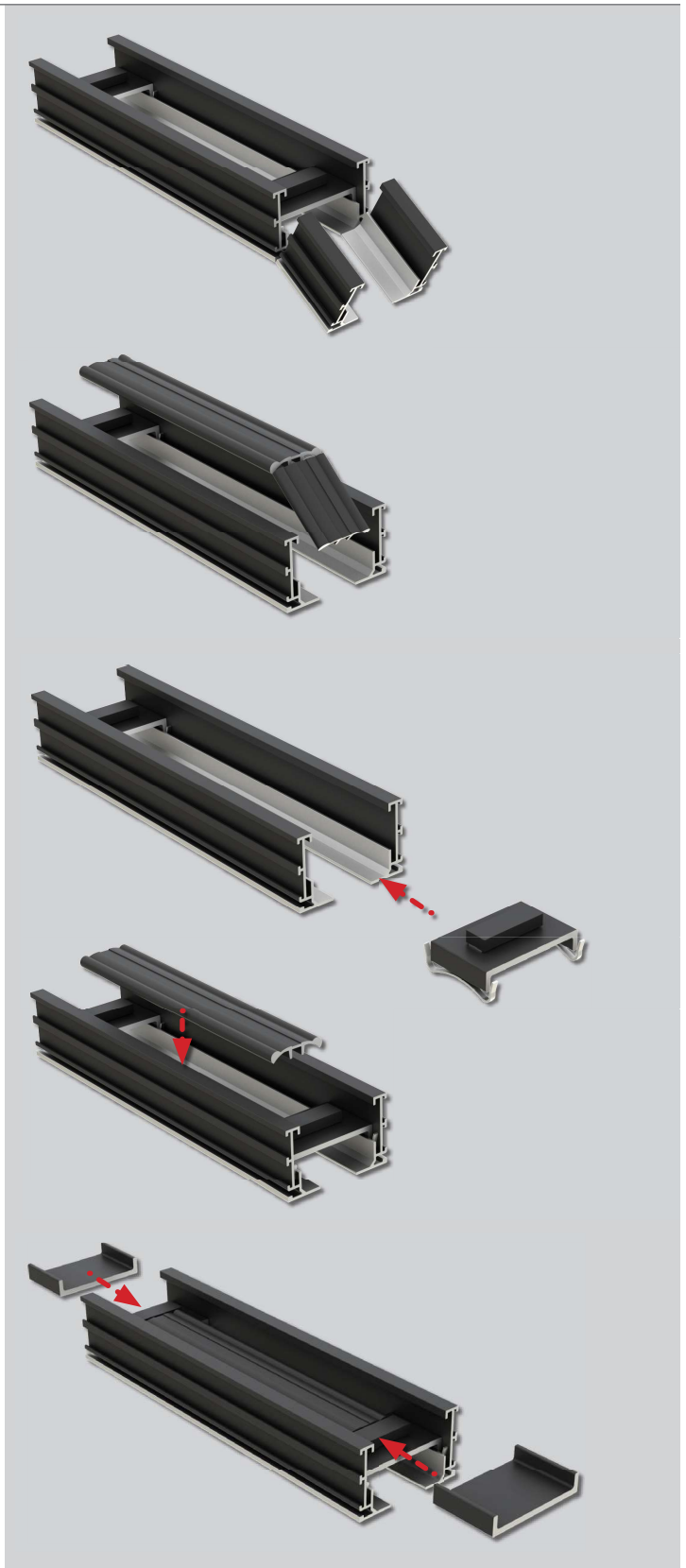

STEP 11

Slide the End Cap / End Plate assembly on to the Frame. Screw the End Cap Mounting Brackets on to the Frame.

STEP 12

Assembly is now complete.



PART IDENTIFICATION

